

# INSTRUCTION MANUAL

## Model: RWB2 Red Wireless Base with 10 year 3V Lithium Battery Backup and Conduit Adaption

### Specifications:

Main Power Source	220-240V ac, 50 Hz
Secondary Power Source	3V Sealed Lithium battery
Operating Current	≤40 mA
Temperature Range	0 °C to 45 °C
Humidity Range	5% to 95%
Interconnecting	Wired/wireless interconnect up to 40 alarms over 150 metres maximum
Transmit Frequency	433.92 MHz
RF Range	100 m free air 30 m indoors (line of sight)
Terminals	Active, Neutral, Loop and Interconnect terminals each accommodates 2×1.5 mm
Pairing duration	2.5 mins (recount after each success pairing)
Visual Indicators	Red LED for pairing, warning and low battery indication
Approval	AS4268, AS/NZS CISPR 32:2015

### Product Description

- The Red Wireless base V2 is specifically engineered for cable/conduit installation, serving as an RF wireless interconnect base intended for use with Red Smoke Alarms R240 and R240RC smoke alarms.
- Not compatible with 3rd party products, systems or fire panels.
- Not compatible with model R10 and R9.
- Achieve wireless interconnection with the RF Lithium Battery powered smoke alarm R10RF.
- This product must be installed by a licensed electrician. Incorrect installation may lead to the risk of fatal electric shock or fire hazard.

### Feature

- There are two available side knockouts for conduit surface mount, each with a knockout space measuring 20x22mm.
- There is one internal knockout available for ceiling internal mount, with a knockout space measuring 17x42mm.
- A RF Pairing Button located on the side allows for easy and efficient wireless pairing.
- A plastic cover is provided to prevent any exposure of cables and wires.

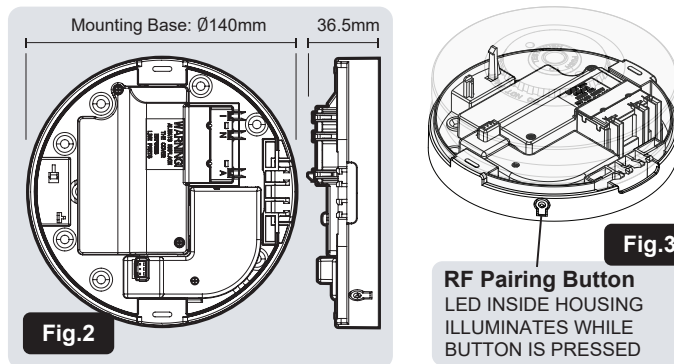
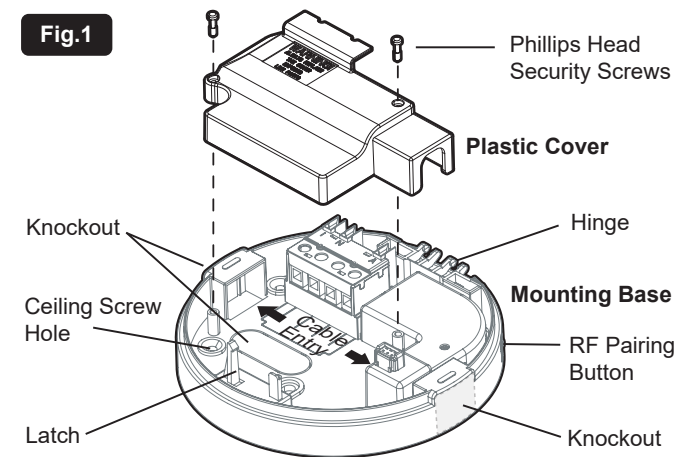

### Wireless Connection Setup Guide:

1. Complete installation and turn on the mains power supply.
  2. Select the wireless base with a smoke alarm as the MASTER unit. Place the MASTER label near the RF pairing button. Treat all other units as BRANCH units.
  3. To initiate the self-learn process on the MASTER wireless base, press and hold the RF pairing button manually for 5 seconds. The unit will enter the self-learn mode, indicated by the LED remaining illuminated for 2.5 minutes.
- NOTE: To exit self-learn pairing mode, press the RF pairing button once. The Red LED will turn off.
4. While the LED of the MASTER unit is illuminated, pair the BRANCH units by quickly pressing their RF pairing button two times. The LED of the BRANCH unit will flash five times, indicating successful interconnection.

If a BRANCH UNIT fails to flash its LED five times, it indicates that the wireless connection has not been successful. In such cases, please verify that the LED of the MASTER unit remains illuminated and is still in self-pairing mode while pairing the BRANCH unit. Ensure that only one unit is designated as the MASTER, while all others are subordinate BRANCH units. If reactivating the master self-pairing mode, previously paired units do not need to be paired again.

5. Repeat step 4 on all other BRANCH units.

6. After all units has been paired, exit self-pairing mode on the master unit, then press and hold the MASTER unit's Test/Hush button until all other wireless RF interconnect units alarm sound (It may take some time for all units to sound the alarm.)

### Hardwire Installation & Interconnect Guide:

WARNING: Please ensure to disconnect the mains power from the circuit.

1. Remove the plastic cover, use a screwdriver to loosen both security screws.
2. To surface mount the device with conduit, remove the two side knockouts. Alternatively, for internal ceiling mounting, remove the internal knockout.
3. Securely attach the mounting base to the ceiling using screws and route the house wires through it.
4. Connect the house wires to the terminal block on the mounting base.

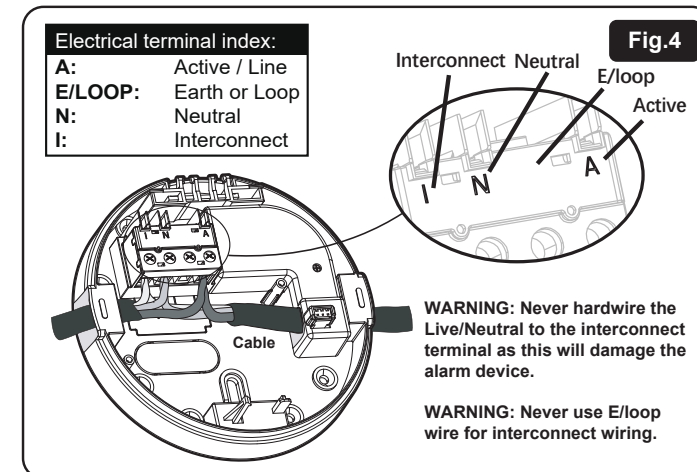

Refer to the manual for more details on the correct circuit wiring.

5. Cover all the wires with the plastic cover, use a screwdriver to tighten the plastic cover with the security screws.
6. Attach the Red Smoke Alarm main unit to the hinge of the mounting base by clipping it, and secure the unit by locking it with the latch.

### IMPORTANT - EQUIPMENT INSTALLATION HAZARD

- Only install indoors.
  - All interconnected smoke alarms (max 40) must be supplied from the same interconnection. A common Neutral must be from the same interconnection. A common Neutral must be used for the interconnect to operate.
  - DO NOT connect the interconnect wire to Active or Neutral.
- WARNING: Failure to follow these instructions may result in equipment damage or injury.**

Fig.5

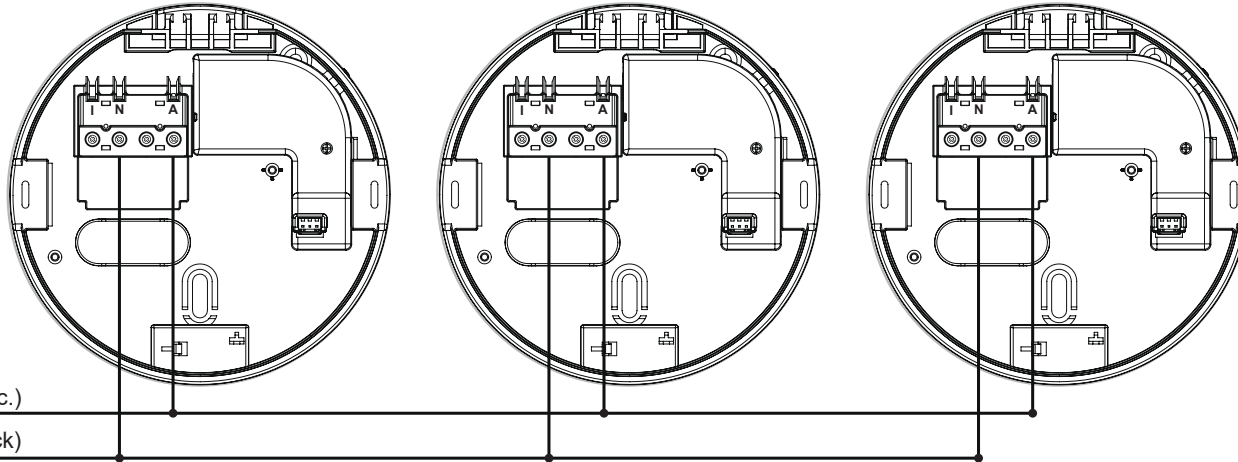

Active (Red)  
220-240V a.c.)

Neutral (Black)

**Note:** Never have hard wire interconnection with multiple RWB2 bases. Multiple RWB2 bases must be connected through RF. RWB2 interconnect terminal is only for connection directly to other smoke alarms and/or heat alarms.

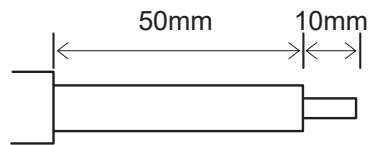

#### NOTICE - EQUIPMENT INSTALLATION COMPLIANCE

Follow National/State Electrical Codes and any local state legislation requirements. Cable sizing must be in accordance with AS/NZS 3000:2018 wiring regulations and adhere to state regulations a minimum of 1.0mm<sup>2</sup> 250 V.

Interconnect cable on alarms must be SDI cable. (No 4core/ aircon wire to be used) Failure to follow will void warranty.

#### CAUTION

- Alternative Energy Sources - (Wind, Solar, UPS etc.) This product is designed to be connected to a Pure or True Sine Wave 230 Vac supply.
- It should not be connected to a power source that utilises an inverter, e.g. PV solar panel, the Total Harmonic Distortion (THD).
- Light Dimmer Circuits – The alarm must not be powered from a light dimmer circuit
- If the Red LED is flashing rapidly (3 times per second) without any sound, it indicates a potential issue with the neutral connection or incorrect wiring.
- Please check wiring and connection of smoke alarms with flashing red LED and rectify wiring issue immediately.
- An optional wireless base [RWB2] may be purchased separately if wired connection is not possible.

#### Warranty

Red Smoke alarms have a service life of 10 years under normal use. Australian Standards stipulate that smoke alarms must be replaced when the alarm reaches 10 years of age from the manufacture date. Red Smoke Alarms warrants this product to be free from defects in materials and workmanship for a period of ten (10) years from the manufacture date of the alarm. This ten (10) year warranty applies to the first purchaser only - for subsequent purchasers, the warranty is five (5) years from the manufacture date.

The RWB2 base and respective 240v components/alarms must be installed by a licensed electrician in accordance to AS3000. Correct polarity must be maintained throughout the circuit and any mixing of the Active, Neutral or Interconnect wires will damage the alarms. It is recommended that a dedicated circuit be used for this system and that the core wiring colours used are properly identified and maintained throughout the installation.

Red Smoke Alarms reserves the right to change specifications, modify designs and discontinue items without incurring obligation whilst every effort is made to ensure that descriptions, specifications and other information in this catalogue are correct, no warranty is given in respect and the company shall not be liable for any error therein.

This material copyright under Australian and international laws. Except as permitted under the relevant law, no part of this work may be reproduced by any process without prior written permission of and acknowledgment to Red Smoke Alarms.



**RED SMOKE ALARMS PTY. LTD.**  
service@redsmokealarms.com.au  
www.redsmokealarms.com.au  
1300 316 552  
© Red Smoke Alarms 2023